

Topic 10

Amplification and Amplifiers

Professor Peter YK Cheung
Dyson School of Design Engineering

URL: www.ee.ic.ac.uk/pcheung/teaching/DE1_EE/
E-mail: p.cheung@imperial.ac.uk



In this lecture, we will consider the idea of amplifying (enlarging) an electrical signal. We will also consider the idea of loading, input resistance, output resistance and gain of an amplifier.

The Idea of amplification

- ◆ Amplification is one of the most common processing functions
- ◆ **Amplification** means making things bigger
- ◆ **Attenuation** means making things smaller
- ◆ There are many non-electronic forms of amplification

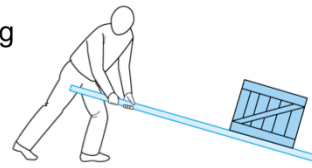

- ◆ **Non-electronic amplifiers: Levers**

- Example shown on the right is a force *amplifier*, but a displacement *attenuator*
- Reversing the position of the input and output would produce a force *attenuator* but a displacement *amplifier*
- This is an example of a **non-inverting amplifier** (since the input and output are in the same direction)

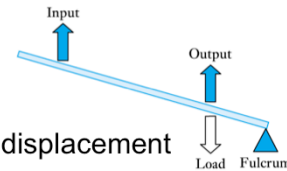

This lecture is about the idea of amplification of electronic signal. In earlier lectures, you learned about voltage divider circuits. It provides ATTENUATION of signals – reducing the voltage level. In this and the next lecture, you learn about how to boost signals instead.

There are many examples of amplification in non-electrical systems. Mechanical lever is one common example. It provides force amplification – a small amount of force is “amplified” to much larger force. However, the displacement is reduced.

This example shows non-inverting amplification because the direction of the input force and the output force are the same.

Another example of amplification

◆ Non-electronic amplifiers

– Pulleys

- Example shown here is a force *amplifier*, but a displacement *attenuator*
- This is an example of an **inverting amplifier** (since the input and output displacements are in opposite directions) but other pulley arrangements can be non-inverting

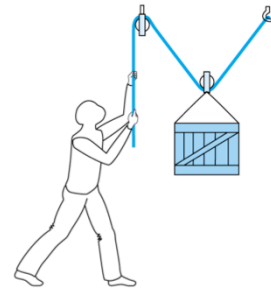

◆ Passive and active amplifiers

- Levers and pulleys are examples of **passive amplifiers** since they have no external energy source
 - In such amplifiers the power delivered at the output must be less than (or equal to) that absorbed at the input
- Some amplifiers are not passive but are **active amplifiers** in that they have an external source of power
 - In such amplifiers the output can deliver more power than is absorbed at the input

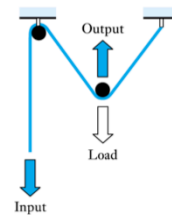

Pulley is another example of amplification. However, in the example shown here, the amplification is inverting. The input and output directions are opposite to each other.

Both lever and pulley are examples of passive amplification – there is no external energy source besides that of the operator(s).

However in electronics, amplification involves using external power source. This is known as active amplification. Active amplification delivers more power at the output than power absorbed at the input. That is, there is a net power gain. An electronic amplifier use up energy from the power source.

Electronic Amplifiers

- ◆ We will concentrate on *active* electronic amplifiers
 - take power from a power supply
 - amplification described by gain

$$\text{Voltage Gain } (A_v) = \frac{V_o}{V_i} \text{ or } 20 \log_{10} \frac{V_o}{V_i} \text{ dB}$$

$$\text{Current Gain } (A_i) = \frac{I_o}{I_i} \text{ or } 20 \log_{10} \frac{I_o}{I_i} \text{ dB}$$

$$\text{Power Gain } (A_p) = \frac{P_o}{P_i} \text{ or } 10 \log_{10} \frac{P_o}{P_i} \text{ dB}$$

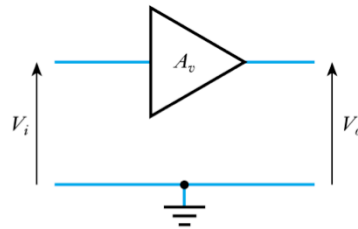

You have seen this slide in an earlier lecture, and it is reproduced here to remind you the three different types of gains.

Here is a symbol we normally use to represent an electronic amplifier, which is connected to an external power source.

Amplification is characterised by its gains, which is the ratio of output to input. The ratio or gain can be in voltage, current or power.

Remember that gain is often expressed in dB. For voltage and current, the gain in dB is 20 times log of the ratio. For power, the multiplying factor is 10 instead of 20.

Sources and Loads

- ◆ An *ideal* voltage amplifier would produce an output determined only by the input voltage and its gain.
 - irrespective of the nature of the source and the load
 - in real amplifiers this is not the case
 - the output voltage is affected by **loading**

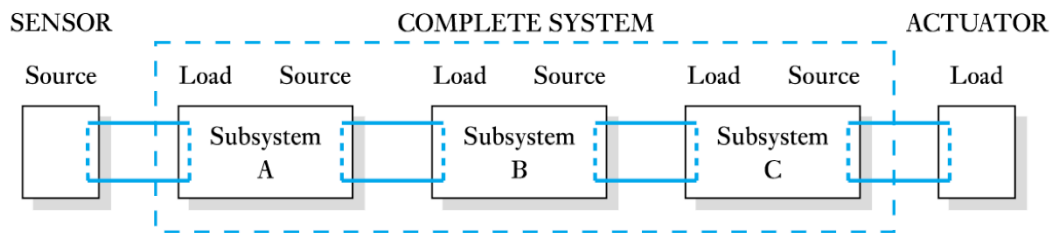

In electronic systems, there can be a number of amplification stages connected in series (also known as cascade). In the system shown here, a sensor may produce the **source** of the electrical signal. This could be passed through three stages to drive an actuator, which is the final **load**.

In an ideal amplifier, the source would have zero source impedance and the load would have infinite load impedance. In which case, the voltage gain would be independent of the source and load.

In practical systems, both source impedance and load impedance would be non-zero and not infinite. In which case, both source and load will affect the actual voltage gain as we will see later.

The concept of non-ideal source and non-ideal load is important in electronics.

Modelling Sources and Loads

◆ Modelling the input of an amplifier

- the input can often be adequately modelled by a simple resistor
- the **input resistance**

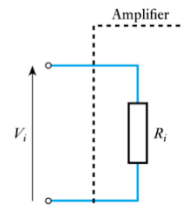

◆ Modelling the output of an amplifier

- Similarly, the output of an amplifier can be modelled by an ideal voltage source and an output resistance.
- This is an example of a **Thévenin equivalent circuit**

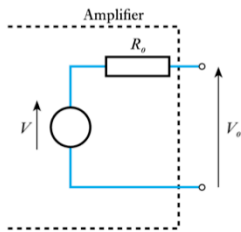

◆ Modelling the gain of an amplifier

- can be modelled by a controlled voltage source
- the voltage produced by the source is determined by the input voltage to the circuit

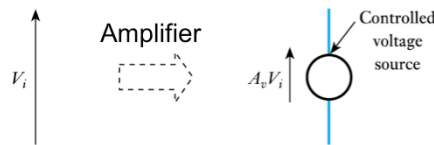

Consider an actual input of an amplifier. Its input can be modelled as an **input resistance** R_i as shown in the figure here. In an ideal amplifier, $R_i = \infty$. In real amplifier R_i is large but finite.

The output of an actual amplifier can be modelled by an ideal voltage source v in series with an **output resistance** R_o as shown. For an ideal amplifier $R_o = 0$. In a real amplifier, R_o is non-zero but usually small.

Finally, the voltage gain of an amplifier is modelled by a **dependent voltage source**. The voltage is dependent on the input voltage and the multiplication factor is A_v , the voltage gain.

Equivalent circuit of an amplifier

- ◆ We can put together the models for input, output and gain, to form a model of the entire amplifier as shown here

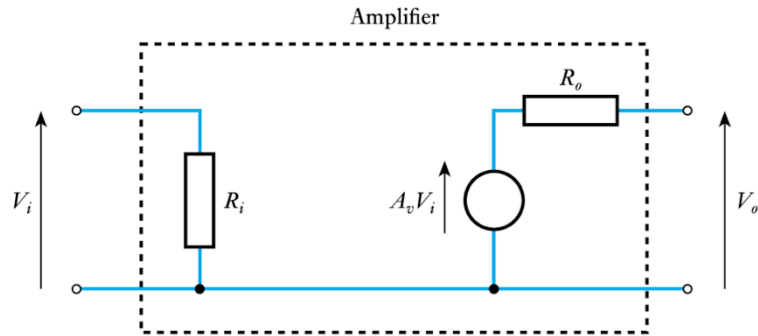

Putting these three elements together, we have a model of an amplifier. This is quite universal.

Please satisfy yourself that this model of an amplifier is linear: it obeys both the principles of **proportionality** and **superposition**.

An example (1)

- ◆ An amplifier has a voltage gain of 10, an input resistance of $1\text{ k}\Omega$ and an output resistance of $10\ \Omega$.
 - ◆ The amplifier is connected to a sensor that produces a voltage of 2 V and has an output resistance of $100\ \Omega$, and to a load of $50\ \Omega$.
 - ◆ What will be the output voltage of the amplifier (that is, the voltage across the load resistance)?
- ◆ We start by constructing an equivalent circuit of the amplifier, the source and the load:

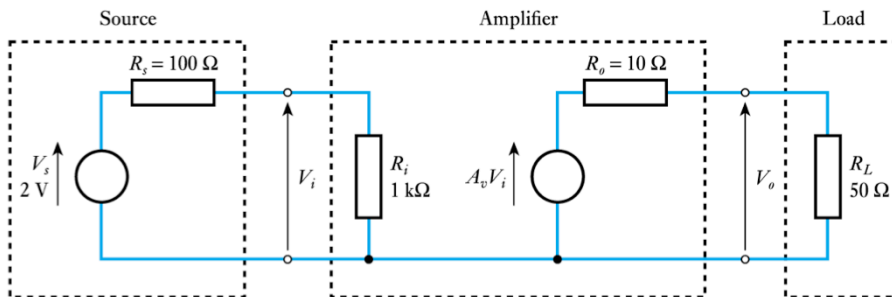

PYKC 26 May 2020

DE 1.3 - Electronics 1

Topic 10 Slide 8

Let us now consider an example. We assume that source voltage is a 2 V battery with a $100\ \Omega$ source resistance R_s . This source signal is applied to the input of an amplifier V_i with a $1\text{ k}\Omega$ input resistance, a gain of 10 and a $10\ \Omega$ output resistance. The output of the amplifier V_o is driving a $50\ \Omega$ load.

This can be modelled as shown in the diagram here.

The question is: what is the output voltage of the amplifier?

An example (2)

- From this we calculate the output voltage:

$$V_i = \frac{R_i}{R_s + R_i} V_s$$

$$= \frac{1 \text{ k}\Omega}{100 \Omega + 1 \text{ k}\Omega} \times 2 \text{ V} = 1.82 \text{ V}$$

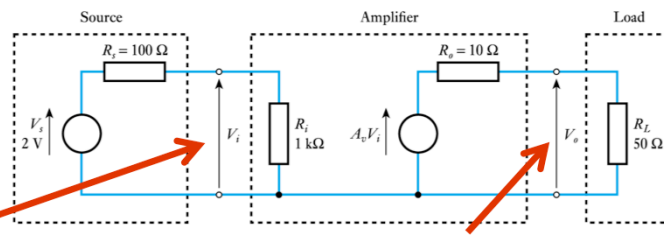

- Although the amplifier has a gain of 10 when it is NOT connected to anything, when used in the system, the actual gain is:

$$\text{Voltage Gain } (A_v) = \frac{V_o}{V_i} = \frac{15.2}{1.82} = 8.35$$

$$V_o = A_v V_i \frac{R_L}{R_o + R_L}$$

$$= 10 V_i \frac{50 \Omega}{10 \Omega + 50 \Omega}$$

$$= 10 \times 1.82 \frac{50 \Omega}{10 \Omega + 50 \Omega} = 15.2 \text{ V}$$

- The reduction of the voltage gain is due to **loading effects**.
- The original gain of the amplifier in isolation was 10. It is the **unloaded** gain.

If the amplifier were ideal, since its voltage gain is x10, we would expect the output to be 20V.

However, both the source and input of the amplifier are non-ideal. Therefore the input of the amplifier has a loading effect on the source voltage. V_i is derived from V_s according to the voltage divider circuit as shown here. Instead of 2V, the amplifier input only sees a 1.82V due to the loading effect of the amplifier on the source.

Similar, the output load R_L has a loading effect on the amplifier output, which is now modelled with the Thevenin equivalent circuit. Similar this is acting as a voltage divider. The output voltage is 15.2V, which is considerably smaller than the 20V as expected with an ideal amplifier (which would have infinite input resistance and zero output resistance).

The effective voltage gain is now only x 8.25 instead of x10.

An ideal voltage amplifier

- ◆ An **ideal voltage amplifier** would not suffer from loading
 - it would have $R_i = \infty$ and $R_o = 0$

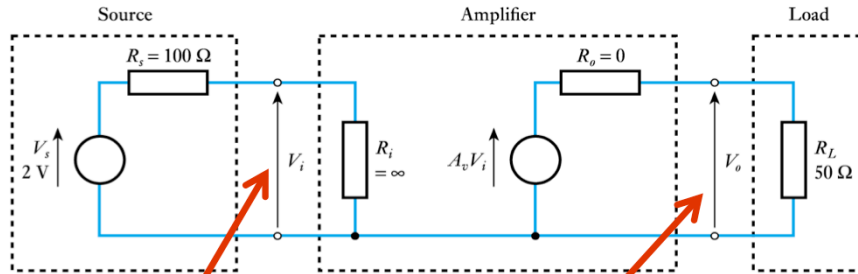

- ◆ If $R_i = \infty$, then

$$\frac{R_i}{R_s + R_i} \approx \frac{R_i}{R_i} = 1$$

- ◆ and,

$$V_i = \frac{R_i}{R_s + R_i} V_s \approx V_s = 2\ \text{V}$$

$$\begin{aligned} V_o &= A_v V_i \frac{R_L}{R_o + R_L} \\ &= 10 V_i \frac{50\ \Omega}{0\ \Omega + 50\ \Omega} \\ &= 10 \times 2 \frac{50\ \Omega}{50\ \Omega} = 20\ \text{V} \end{aligned}$$

Here is the calculation again, assuming an ideal amplifier.

Frequency response and bandwidth of Amplifier

- ◆ All real amplifiers have limits to the range of frequencies over which they can be used.
- ◆ The gain of a circuit in its normal operating range is termed its **mid-band gain**.
- ◆ The gain of all amplifiers falls at high frequencies.
 - Characteristic defined by the **half-power point**.
 - Gain falls to $1/\sqrt{2} = 0.707$ (-3dB) times the mid-band gain.
 - This occurs at the **cut-off (or corner) frequency**.
- ◆ In some amplifiers gain also falls at low frequencies.
 - These are **AC coupled amplifiers**
- ◆ The **bandwidth** of the amplifier is the frequency range up to the -3dB point (or cut-off frequencies)

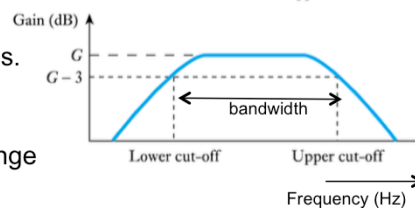
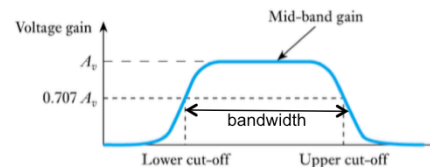
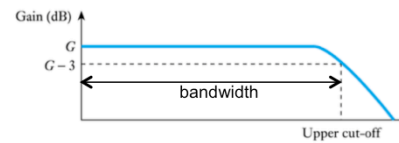

In the previous example, the source signal is a dc voltage at 2V. In general, the source signal can be of any frequency. DC voltage is only a special case where the frequency is 0.

In real amplifiers, the gain of the amplifier is NOT constant for ALL frequencies. Most amplifier will have a gain that drops off at some upper frequency. We call this the cut-off frequency or corner frequency (as in RC circuit we looked at in Lecture 10). It is called cut-off frequency because beyond this, the output signal starts to fall (hence cutting off signal components at this and high frequencies).

The cut-off frequency is defined the frequency at which the power is reduced by half. Since voltage is proportional to square root of power, the half-power frequency corresponds to that where the voltage gain is reduced by a factor of $1/\sqrt{2}$ or -3dB.

The gain at the “normal operating frequency” is known as the mid-band gain.

Amplifier can also discriminate (i.e. suppress) signals at lower frequencies such as DC. We call this AC coupled amplifier because it only passes AC signals.

The bandwidth of an amplifier is the frequency range from 0 to the upper -3dB frequency for a DC coupled amplifier, or between the lower and the upper -3dB frequencies for a AC coupled amplifier.

Differential amplifiers

- ◆ Differential amplifiers have two inputs and amplify the voltage difference between them.
 - Inputs are called the **non-inverting input** (labelled +) and the **inverting input** (labelled -)

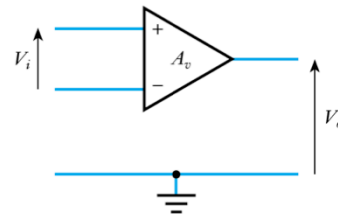

- ◆ An example of the use of a differential amplifier:

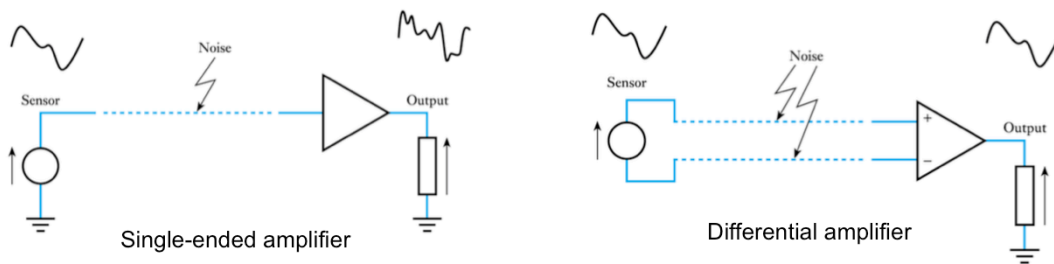

PYKC 26 May 2020

DE 1.3 - Electronics 1

Topic 10 Slide 12

So far, we have only consider amplifiers that takes an input signal with one terminal, which is always referenced to GROUND. We call this a single-ended signal. The amplifier is known as a single-ended amplifier.

Single-ended amplifier is susceptible to picking up unwanted noise signal.

Another type of amplifier has two input signals, labelled +ve and -ve inputs. The amplification is provided on the difference between V^+ and V^- input (i.e. $V_o = A_v \times (V^+ - V^-)$).

The advantage of a differential amplifier is that any noise picked up by the two input signal wires are cancelled out if the noise signals on both wires are identical. The (noise) signal that is common to both inputs is known as “common-mode” signal. The signal that is difference between the two inputs is known as “differential signal”. A differential amplifier only provides amplification to the differential signal. The common-mode signal is complete suppressed, or rejected.

We can find such a differential amplifier everywhere. For example, the land line in your home uses a differential signal and the phone has a differential amplifier. In that way, your phone conversation is still clear even if someone is vacuuming the carpet! In order to ensure that the noise pick-up on both signal wires are the same, the phone wire is twisted together, so that both wire on average is of the same distance to the noise source.

Equivalent circuit of a differential amplifier

- ◆ In Lab 3, we will be using a common differential amplifier called **operational amplifier (OpAmp)**.
- ◆ The equivalent circuit of such a differential amplifier is:

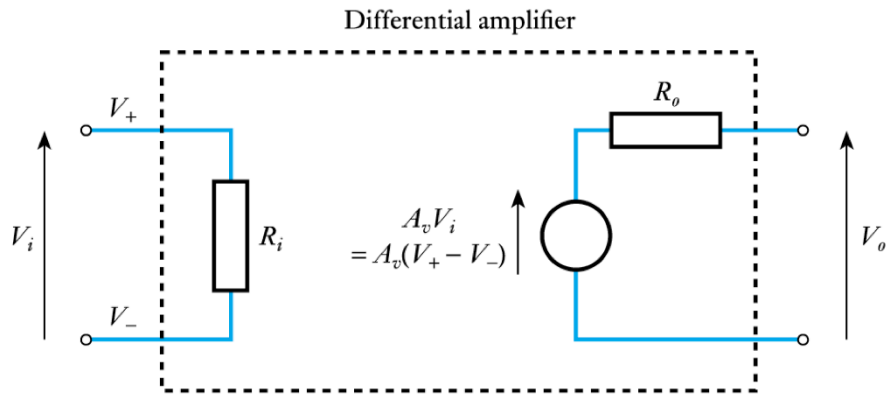

You will be using a very common type of differential amplifier in Lab 3. These are called operational amplifiers or OpAmp's for short. The model for a differential amplifier (including an OpAmp) is shown here.